

Mönninghoff

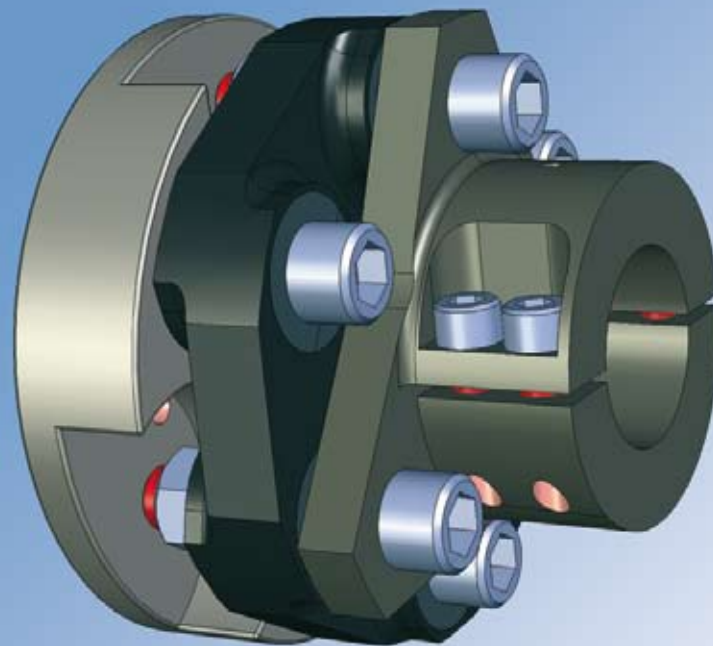

BLUE-Line by SGF/MMB

The Newest Marine Coupling Technology



HexaFlex-Blue by SGF

More details see overleaf.

Contact:

SGF GmbH & Co. KG

Graslitzer Str., 84478 Waldkraiburg, Germany
Phone +49-8638-605 0, Fax +49-8638-605 111
vertrieb-tec@sgf.de, www.sgf.de

Maschinenfabrik Mönninghoff GmbH & Co. KG

Bessemerstr. 100, 44793 Bochum, Germany
Phone +49-234-3335 0, Fax +49-2343335200
sales@moenninghoff.de, www.moenninghoff.de



HexaFlex-Blue Couplings. For a quiet marine driveline.

- Mounts on the output side between gearbox and shaft
- Reduces vibrations in the body of the boat
- Extends the life of surrounding drivetrain components
- Standard solutions for ZF- und YANMAR gearboxes
- Customized solutions on request

Advantages:

- Transfer of high torque with a small coupling size
- No additional adapters necessary
- Eliminates axial and radial misalignments
- Cord inlays in the coupling eliminate axial forces generated by the transmission of torque
- Customized hole patterns can be made upon request
- Easy mounting without moving the gearbox or propeller shaft
- Made of stainless steel
- Suitable for aluminium boats
- Long life and absolutely maintenance free

Contact:

SGF GmbH & Co. KG

Graslitzer Str., 84478 Waldkraiburg, Germany
Phone +49-8638-605 0, Fax +49-8638-605 111
vertrieb-tec@sgf.de, www.sgf.de

Maschinenfabrik Mönninghoff GmbH & Co. KG

Bessemerstr. 100, 44793 Bochum, Germany
Phone +49-234-3335 0, Fax +49-2343335200
sales@moenninghoff.de, www.moenninghoff.de